

6100 SERIES

MEDIUM INTENSITY RUNWAY LIGHT

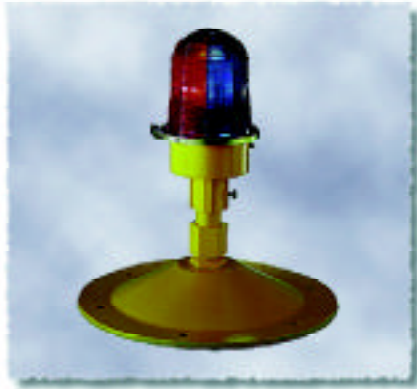

Fixture shown mounted on #1080 Baseplate

The 6100 Series Medium Intensity Light is used for elevated runway edge, taxiway and threshold/end lighting.

The fixtures are certified to FAA L-861, L-861T and L-861E under Advisory Circular 150/5345-46 and meet the requirements of ICAO Annex 14.

The 6100 series fixture is a die cast aluminum fixture body which supports a single lens in a precise position with respect to the prefocused filament of the lamp. Lenses are either solid or split combination colored. The basic fixture assembly includes lens gasket, lens clamp band, upright tube, secondary cable assembly and 1-1/2" threaded Frangible Coupling.

L-861 Runway and L861T Taxiway fixtures use either a 30W or 45W 6.6A lamp. For L-861E Threshold/end lights, a 45W 6.6A lamp is used. Lamps can be either T10 Incandescent or Bi-pin Quartz. A 40W, 120V medium screw shell Traffic Signal lamp is available for multiple wired installations.

The standard mounting height for these fixtures is 14". Fixtures can be furnished up to 30" in height upon special order.

ORDERING INFORMATION

Basic Fixture Assembly

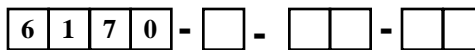

Lamp Type*:

H = Bi-pin Quartz

M = Incandescent/Medium Screw

Color/Color:

A = Amber

B = Blue

G = Green

O = Obscure (Blank)

R = Red

W = White (Clear)

*No designation used for Incandescent

Medium Prefocused

Fixture Mounting Height, inches:
Standard Height is 14"

20 = 20"

24 = 24"

30 = 30"

Fixtures over standard height include longer cable and extra length thinwall cut to proper length.

How to order:

Add optional items to basic fixture assembly in the following manner:

Choose lamp type desired. Add color and height requirements.

Examples:

(1) 6170-AW-20 is a L861 Runway Light, with prefocused socket for T10 type lamp, with Amber/White lens, 20" high.

(2) 6170-H-RG-30 is a L861E Threshold Light, with Bi-pin socket for quartz lamp, with Red/ Green lens, 30" high.

Note: Lamp must be ordered separately

Multi

ELECTRIC

The Quality Approach

Accessories

Catalog Number	Description
1080	Baseplate, 1-1/2" tap, Aluminum
1935	Baseplate, 1-1/2" tap, Steel
1090	Stake Assembly, 1-1/2" tap
9621	30W 6.6A T10 Incandescent Lamp
9623	45W 6.6A T10 Incandescent Lamp
9699-1	30W 6.6A Bi-pin Quartz Lamp
9699-2	45W 6.6A Bi-pin Quartz Lamp
9620-1	40W, 120V Traffic Signal Lamp

Replacement Parts

Catalog Number	Description	Catalog Number	Description
6170	Basic Fixture Assembly, Incandescent	1090-01	Mounting Stake, Angle
6170-H	Basic Fixture Assembly, Quartz	1090-03	Stake Fitting, 1-1/2" tap
6170-M	Basic Fixture Assembly, 120V	6170H-04	Lamp Support Standoff, Quartz
964	Frangible Coupling	861-FA	Amber Lens
980-5	Lamp Socket, Incandescent, prefocused	980-FB	Blue Lens
6370-04	Lamp Socket, Quartz, bi-pin	861-FG	Green Lens
4610-3	Lamp Socket, Incandescent, screw shell	861-FR	Red Lens
6170-05	Lens Clamp Band	861-FW	White (Clear) Lens
6183-07	Lens Gasket	861-FAR	Amber/Red Lens
1170-16	Cable Assembly, 16" long	861-FAW	Amber/White Lens
1170-32	Cable Assembly, 32" long	861-FGR	Green/Red Lens
1070-08A	1" Thinwall Tube, 3-3/4" (14"h)	980-FBO	Blue/Obscure Lens
1070-08B	1" Thinwall Tube, 15-3/4" (20"h)	861-FRB	Red/Blue Lens
1070-08C	1" Thinwall Tube, 19-3/4" (24"h)	861-FRW	Red/White Lens
1070-08D	1" Thinwall Tube, 26" (30"h)	962-2	Baseplate Gasket

BASE MOUNTED MARKER LIGHT

FIXTURE SHOWN WITH OPTIONAL EXTRA HEIGHT

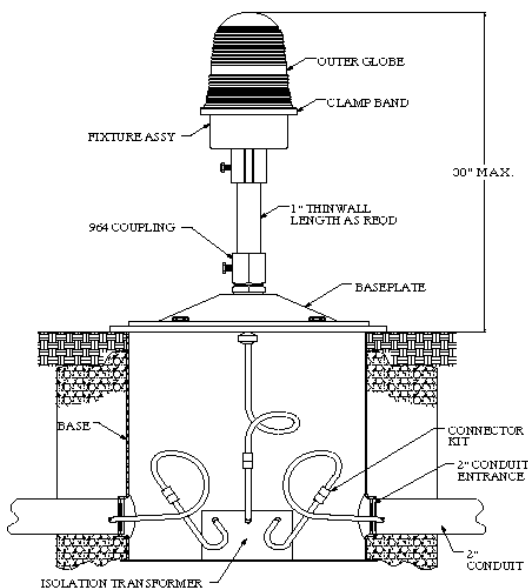

STAKE MOUNTED MARKER LIGHT

FIXTURE SHOWN WITH OPTIONAL EXTRA HEIGHT

