

6370SE

MEDIUM INTENSITY THRESHOLD LIGHT



Fixture shown with #961 Frangible Coupling and #1170-03 Baseplate

The 6370SE Medium Intensity Light is used for elevated threshold/end lighting.

The fixtures are certified to FAA L-861SE under Advisory Circular 150/5345-46 and meet the requirements of ICAO Annex 14.

Die cast aluminum fixture body supports a clear smooth heat resistant outer dome and colored inner lenses in a precise position with respect to the prefocused filament of the lamp. Fixtures mount directly on 2" Frangible Coupling or on 2" EMT with EMT Frangible Coupling.

L-861SE threshold/end lights use a 120W 6.6A quartz lamp. Easy lamp replacement is accomplished by loosening one thumbscrew and lifting entire optic lens assembly from base unit.

ORDERING INFORMATION

Basic Fixture Assembly



Color/Color:

G = Green

O = Obscure (Blank)

R = Red

W = White (Clear) (not FAA certified)

A = Amber (not FAA certified)

B = Blue (not FAA certified)

omit for Basic Fixture Assembly only

Fixture Mounting Height, inches:

Standard Height is 10"

14 = 14"

20 = 20"

24 = 24"

30 = 30"

Fixtures over standard height

include longer cable and 2" EMT

cut to proper length.

How to order:

Add optional items to basic fixture assembly in the following manner:

Add color and height requirements.

Examples:

(1) 6370SE-24 is the Basic Fixture Assembly, less lenses, for 24" high mounting.

(2) 6370SE-GO-20 is a L861SE Unidirectional Threshold Light, with Green light on one side and no light (Obscured) on other side, 20" high.

(3) 6370SE-RG-30 is a L861SE Bidirectional Threshold Light, with Red light on one side and Green light on other side, 30" high.

Note: Lamp and Frangible Coupling to be ordered separately

Accessories

Catalog Number	Description
1170-03	Baseplate, 2" tap, Aluminum
1932	Baseplate, 2" tap, Steel
2102	Stake Assembly, 2" tap
961	2" Slip type Frangible Coupling
961-AG	2" EMT Frangible Coupling
9696	120W 6.6A Bi-pin Quartz Lamp

Replacement Parts

Catalog Number	Description	Catalog Number	Description
6370SE	Basic Fixture Assembly, 14"h max	6370-08-16	2" EMT, 16" long (24"h)
6370SE-L	Basic Fixture Assembly, 30"h max	6370-08-22	2" EMT, 22" long (30"h)
6370-01	Lens Mounting Casting	6370-09SE	Clear Outer Lens
6370-02	O" Ring Gasket	6370-10G	Green Inner Lens, 177°
6370-03	Lamp Pad	6370-10R	Red Inner Lens, 177°
6370-04	Lamp Socket	6370-100	Obscure Inner Lens, 177°
6370-05	Clamp Band	1170-16	Cable Assembly, 16" long
6370-08-6	2" EMT, 6" long (14"h)	1170-32	Cable Assembly, 32" long
6370-08-12	2" EMT, 12" long (20"h)		

BASE MOUNTED ELEVATED LIGHT FIXTURE SHOWN WITH OPTIONAL EXTRA HEIGHT

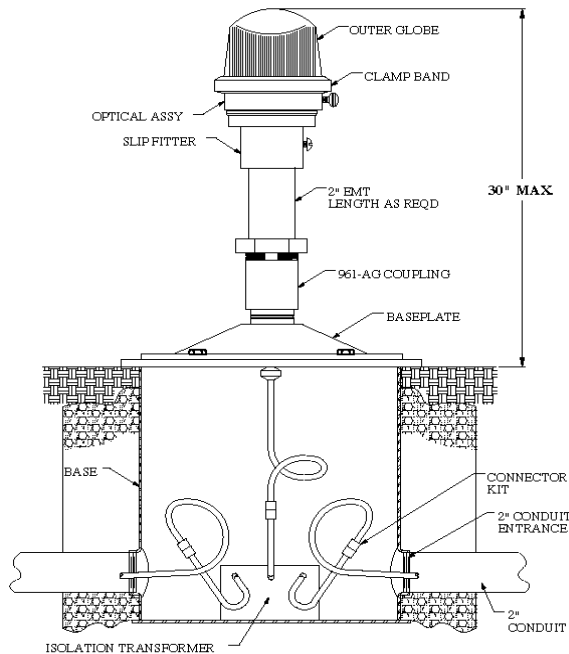

STAKE MOUNTED ELEVATED LIGHT FIXTURE SHOWN WITH OPTIONAL EXTRA HEIGHT

